



ALPHAFLOOR®

THE SOLID CONCRETE FLOOR PANEL

ALPHAFLOOR®

**ALPHAFLOOR® IS THE ONLY COST EFFECTIVE,
SOLID CONCRETE FLOOR SYSTEM AVAILABLE IN THE
AUSTRALIAN CONSTRUCTION INDUSTRY.**

- **SOLID CONCRETE PANEL**
- **HIGHEST PERFORMING ACOUSTIC PRODUCT AVAILABLE TO
MINIMISE SOUND TRANSFER BETWEEN LEVELS**
- **SIGNIFICANT IMPROVEMENT TO NATHERS/BASIX STAR
RATING OF HOME**
- **LOWER COST THAN FIBRE CEMENT FLOORING**
- **STRONG, DURABLE, IMPACT & ABRASION RESISTANT**
- **NO NEED TO PROTECT FROM WATER, RAIN OR TRAFFIC**
- **HIGHLY SUITABLE FOR FLOOD PRONE AREAS**
- **REAL SOLID CONCRETE FEEL & SOUND**
- **NON-COMBUSTIBLE**
- **COMPLIANT WITH ALL 6 BUSH FIRE ATTACK (BAL) LEVELS**
- **AUSTRALIAN MADE & OWNED**
- **ISO 9001 ACCREDITED**



Global-Mark.com.au®

TESTIMONIALS

FOWLER HOMES - CHRISTIAN ROMANO – ESTIMATING AND PROCUREMENT MANAGER & STEVE LICASTRO – CONSTRUCTION MANAGER

“ALPHAFLOOR IS A FANTASTIC PRODUCT AND ONE THAT REALLY ALIGNS WITH OUR BRAND OF BUILDING A QUALITY HOME WITH INNOVATIVE PRODUCTS. WE WOULD RECOMMEND THIS PRODUCT TO ANYONE WANTING A SOLID CONCRETE FEEL WITH THE ADDED BENEFIT OF BOOSTING THE BASIX STAR RATING AT THE SAME TIME.”

ANDREW W, SYDNEY CONSTRUCTION GROUP

“I RECENTLY HAD THE XCEM ALPHAFLOOR SYSTEM INSTALLED IN MY LATEST PROJECT, AND I COULDN’T BE MORE IMPRESSED. THE LIGHTWEIGHT, DENSE CONCRETE PANELS PROVIDE THE FEEL OF A REAL CONCRETE SLAB WHILE SIGNIFICANTLY REDUCING SOUND TRANSFER FROM UPSTAIRS. THE DIFFERENCE IN NOISE LEVELS IS REMARKABLE! I CAN CONFIDENTLY SAY I WILL NEVER USE ANOTHER FLOOR SYSTEM FOR TIMBER FRAME CONSTRUCTION AGAIN. I HIGHLY RECOMMEND XCEM ALPHAFLOOR FOR ANYONE LOOKING TO TAKE THEIR PROJECT TO THE NEXT LEVEL.”

ANDREW STRACHAN, CONSTRUCTION MANAGER

"I AM ABSOLUTELY BLOWN AWAY BY HOW THIS FLOOR FEELS, IT IS ROCK SOLID! THE FLOOR FEELS EVERY BIT AS GOOD AS A SUSPENDED SLAB ON A DOUBLE BRICK HOME. THIS PRODUCT HAS FAR EXCEEDED MY EXPECTATIONS. I AM CONVERTED."

LANCE PANERAS, GENERAL MANAGER, WINCREST GROUP

"THE TEAM AT XCEM REALLY HAVE COME UP WITH A GREAT PRODUCT AND PROJECT DELIVERY SERVICE, WHICH WILL BE A REAL DIFFERENCE MAKER IN THE RESIDENTIAL CONSTRUCTION MARKET FOR YEARS TO COME! I LOOK FORWARD TO WORKING WITH THEM AND THE LATEST INNOVATIONS THEY COME UP WITH IN FUTURE, IN ORDER TO INTEGRATE THOSE INTO MANY MORE WINCREST BUILDS FOR YEARS TO COME."

ALEX ILIC, DIRECTOR, PIROSSI DEVELOPMENTS

“WE FOUND XCEM ALPHAFLOOR ONLINE AND WERE ABSOLUTELY BLOWN AWAY AT THIS PRODUCT AT FIRST GLANCE. ONCE WE SAW THE PRODUCT IN PERSON IT WAS A NO BRAINER TO UTILISE THIS ON OUR HIGH END PROJECTS. VERY HAPPY WITH THE PRODUCT, THE TEAM AT XCEM WERE GREAT ALL THE WAY THROUGH THE JOURNEY.

ALREADY USING THIS PRODUCT ON ANOTHER JOB AND LOOKING FORWARD TO MANY MORE. ALLHAFLOOR IS LEAGUES ABOVE AAC OR YELLOW TONGUE FLOORING!”

BENEFITS OF ALPHAFLOOR®

FOR THE FIRST TIME EVER, HOMEOWNERS CAN NOW HAVE A SOLID CONCRETE FLOOR AT AN AFFORDABLE PRICE POINT.

- 01 HIGH-PERFORMANCE CONCRETE AT THE RIGHT PRICE**

ALPHAFLOOR® is solid, high-strength concrete, yet is incredible affordable. ALPHAFLOOR® is the ONLY cost effective concrete-slab substitute.
- 02 SIGNIFICANT IMPROVEMENT TO NATHERS/BASIX STAR RATING**

There are cost savings available when substituting ALPHAFLOOR® for particle board on the first floor, driven by the high thermal mass of the product and the 7 star NatHERS/BASIX requirements.
- 03 SOLID CONCRETE FLOOR FEEL & SOUND**

ALPHAFLOOR® feels and sounds like a concrete slab. The ALPHAFLOOR® floor system is the highest acoustic performing system available. Even outperforming a 150mm concrete slab.
- 04 DURABILITY PROVIDES PEACE OF MIND**
 - Unlike alternative flooring materials ALPHAFLOOR® can be left exposed to the elements indefinitely. ALPHAFLOOR® does not need to be kept dry, and does not need to be waterproofed within a set time period.
 - Moisture will not cause ALPHAFLOOR® to lift.
 - ALPHAFLOOR® is solid concrete - Cut edges do not require coating or sealing as is typically required for substitute FC & AAC products.
- 05 CRYSTALLINE SILICA FREE**

ALPHAFLOOR® contains NO crystalline silica, eliminating risk of development of silicosis through inhalation of dust.
- 06 FAST**

A typical floor is installed in approximately one day. Because the product is concrete, it can easily accommodate all floor finishes including, carpet, tiles, hybrid and hardwood flooring.
- 07 AUSTRALIAN MADE & OWNED**

ALPHAFLOOR® is 100% Australian Made & Owned. ALPHAFLOOR® is manufactured at XCEM's state-of-the-art manufacturing facility located in the Southern Highlands of New South Wales.

THE QUIETEST FLOOR SYSTEM

ALPHAFLOOR® has been thoroughly tested and proven to be Australia's highest acoustic performing floor system. Performing even higher than a 150mm suspended concrete slab. The table below presents a comparison of the common floor systems.

	Airborne Sound Transmission (Rw + Ctr)	Airborne Sound Transmission (DnTw + Ctr)	Impact Insulation (LnTw)
	<i>Higher = Better</i>	<i>Higher = Better</i>	<i>Lower = Better</i>
19mm Particleboard	~40 dB	~35 dB	~85 dB
75mm AAC	48 dB	43 dB	70dB
100mm Concrete Slab	50 dB	45 dB	73 dB
150mm Concrete Slab	52 dB	47 dB	63 dB
35mm ALPHAFLOOR	60 dB	55 dB	54 dB
<i>NCC Requirement for Class 2 & 3</i>	<i>≥ 50 dB</i>	<i>≥ 45 dB</i>	<i>≤ 62 dB</i>

FLOOR SYSTEM DESCRIPTIONS & NOTES

- **19mm Particleboard:** Timber flooring + 19mm Particleboard floor system + R1.5 Glasswool Insulation + 10mm Plasterboard Ceiling (Direct Fixed)
- **75mm AAC:** Timber flooring + Battens + PVC + 75mm AAC + Furring Channel with resilient mounts + R2 Acoustic insulation + 13mm plasterboard ceiling fixed to furring channel.
- **100mm Concrete Slab:** Timber flooring + 100mm Concrete Slab + 10mm Suspended Plasterboard Ceiling
- **150mm Concrete Slab:** Timber flooring + 150mm Concrete Slab + 10mm Suspended Plasterboard Ceiling
- **35mm ALPHAFLOOR®:** Timber flooring + 35mm ALPHAFLOOR® System + R4 Standard Thermal Insulation + 10mm Plasterboard Ceiling (Direct Fixed)
- Lab Results (Rw+ Ctr/Lnw) were assumed to have a ~5 dB difference than infield results (DnTw/LnTw) as per NCC
- R4 Insulation utilised in the ALPHAFLOOR® test was standard thermal insulation, which does not perform as well as acoustic insulation does. If this test had utilised R2 acoustic insulation it is expected that the Rw + Ctr for the floor system would have been marginally higher (~2 dB)

TYPICAL UPGRADE COSTS - PROJECT HOME BUILDERS

When upgrading from standard 19mm particleboard flooring to a suspended concrete slab on the first floor, homeowners can expect to pay approximately \$250,000 dollars more! This is to cover the cost increase of the slab, beams, and structural walls required to carry the slab. By comparison homeowners will only pay approximately \$15,000 extra to upgrade to the solid concrete ALPHAFLOOR system!

The great news for homeowners is that not only is this a saving of ~\$235k compared to a suspended concrete slab, but also that ALPHAFLOOR actually has significantly higher acoustic performance than a suspended concrete slab! Providing 8dB higher performance for Airborne Noise and 9dB higher performance for impact insulation.

The other important factor which homeowners need to be aware of is project timeline implications. Upgrading to a suspended concrete slab will add ~ 4 weeks to the construction timeline. Compare this to ALPHAFLOOR which only adds ~ 4 hours compared to 19mm particleboard construction.

	ALPHAFLOOR Solid concrete floor system	Suspended Concrete Slab	Particleboard Floor System
Typical Cost Increase	\$15k, includes material, installation, and any changes to joist layout	\$250k, includes cost for reinforced beams and load bearing walls	-
Structural Upgrades	No	Yes	-
Project Time Line Increase Compared to Particle Board Floor System	4 Hours	4 Weeks	-
Airborne Sound Transmission	Rw + Ctr 60	Rw + Ctr 52	Rw + Ctr 40
Impact Insulation	LnTw 54	LnTw 63	LnTw 85

FLOOR SYSTEM COMPARISON

Presented below is a comparison of 35mm ALPHAFLOOR® with 75mm AAC Panels, FC Sheets & Particle Board.

	35mm ALPHAFLOOR®	75mm AAC Panel	19/22mm FC Sheet	19/22mm Particle Board
Material	Solid Concrete Panel	Autoclaved Aerated Concrete	Fibre Cement	Particle Board
Thickness	35mm	75mm	19/22mm	19/22mm
Compressive Strength	25 MPa	3 MPa	N/A	N/A
Contains Crystalline Silica (Severe Health Hazard)	No	Yes	Yes	No
Durability - AS/NZS 4456.10	Yes	No	No	No
Requires Protection from Water	No	Yes	Yes	Yes
Sound Insulation Floor System (DnTw + Ctr)	55	43	NA	~32
High Water Absorption (Porosity)	No	Yes	No	Yes
Risk of Corrosion	No	Yes	No	No
Low Maintenance	Yes	No	No	No
Non-Combustible	Yes	Yes	No	No

TECHNICAL SPECIFICATIONS

ALPHAFLOOR® is a solid precast concrete panel made using XCEM® concrete technology. It presents a hard, smooth surface. Table 2.1 contains the material properties of ALPHAFLOOR®. Testing was carried out by a laboratory accredited by NATA for Technical Competence (Accreditation No. 1393, Site No. 1386). The determination of characteristic strength and connection capacity values has been carried out in accordance with AS/NZS1170.0 Appendix B.

ALPHAFLOOR®

PRODUCT	PANEL WIDTH	AVAILABLE LENGTHS (MM)	# PANELS PER PACK
35MM ALPHAFLOOR®	570MM	2700MM	14

Design Density: 40.79 kg/m²

Transport & Construction Density: 52 kg/m²

XCEM ALPHAFLOOR is a precast concrete panel. Tolerances on the manufactured product are:

- Panel short edges +/- 4mm tolerance
- Panel long edges +/- 4mm
- Panel thickness within + 1.5mm tolerance

LOAD CAPACITY OF ALPHAFLOOR®

Application	Permanent Actions Included in Application (35mm)	Distributed Imposed Action Q	Concretrated Imposed Action Q _c (area distributed over)	Maximum Joist Spacing for AlphaFloor®
Residential Activities - General Areas	G _{sw} = 0.40 kPa G _r = 0.25 kPa G _s = 0.50 kPa	1.5 kPa	1.8 kN (350 mm ²)	600 mm
Residential Activities - Tiled Wet Areas	G _{sw} = 0.40 kPa G _r = 0.50 kPa G _s = 0.50 kPa	1.5 kPa	1.8 kN (350 mm ²)	500 mm
Residential Activities - Balconies and Verandahs	G _{sw} = 0.40 kPa G _r = 1.00 kPa G _s = 0.50 kPa	2.0 kPa	1.8 kN (350 mm ²)	450 mm
Light Commercial Activities	G _{sw} = 0.40 kPa G _r = 1.00 kPa G _s = 0.50 kPa	3.0 kPa	2.7 kN (0.01 m ²)	450 mm

Notes:

1. G_{sw} = permanent action due to self-weight of ALPHAFLOOR - 0.40 kPa 35mm
2. G_r = permanent action of applied floor coverings
3. G_s = permanent action allowance for superimposed loading of permanent fixtures
4. Applicable factored load case for strength: 1.2G + 1.5Q

MODELLING ALPHAFLOOR FOR NATHERS

ALPHAFLOOR has been approved by NatHERS and added into the NatHERS Material library. It is listed under the new material "Fibre reinforced concrete (Thermal conductivity = 0.28 W/mK, Heat Capacity 1.172 J/gK) option for ALPHAFLOOR".

Incorporation of ALPHAFLOOR generally adds 0.2 - 0.5 star rating compared to traditional flooring due to its significant thermal mass contribution (depending on orientation, climate zone etc.).

Below is how ALPHAFLOOR is modelled in the various software providers:

- BERS Pro: 35mm XCEM ALPHAFLOOR is available as a standard floor assembly option "35mm fibre reinforced concrete floor".
- Hero: 35mm XCEM ALPHAFLOOR is available as a standard floor assembly option "35mm ALPHAFLOOR".
- FirstRate 5: NatHERS have advised that when using FR5 35mm ALPHAFLOOR to be modelled as 42mm Fibre Cement (Not Compressed Fibre Cement). First Rate 5 have advised that they will look to add ALPHAFLOOR in the next minor update, at which point the users will need to select "35mm Fibre Reinforced Concrete" as opposed to 42mm of FC.

Below are two recent case studies:

1. HOME IN SUTHERLAND -

- When using particle board to first floor achieved 7 stars with the following: R4.5 to external walls (R2.5 batts + R2.0 foam boards); R6.5 to ceiling; R6.0 to framed floor ; Double glazed low-e windows; R2.0 to internal unconditioned walls; 1 x 1400mm ceiling fan to bedroom 1; 1 x 1400mm ceiling fan to bedroom 2; 1 x 2400mm ceiling fan to kitchen/living
- When using 35mm ALPHAFLOOR to first floor achieved 7 stars with the following: R4.5 to external walls (R2.5 batts + R2.0 foam boards); R6.5 to ceiling; R6.0 to framed floor; Double glazed low-e sliding door; Single glazed low-e to other windows; R2.0 to internal unconditioned walls; 1 x 1400mm ceiling fan to bedroom 1; 1 x 2400mm ceiling fan to kitchen/living

2. NEW HOME IN WEST PENNANT HILLS -

- When using particle board to first floor achieved 7 stars with the following: Ceiling insulation to R6.0 (Excl. Garage); External wall insulation to R2.5 (Excl. Garage); R2.5 insulation throughout the internal walls; 1 x 1200mm ceiling fans to Kitchen/Living/Dining; 1200mm ceiling fans to all Bedrooms, Rumpus, Media; Double glazed low-e to all windows and sliding doors; R4.0 Insulation throughout the suspended floor
- When using 35mm ALPHAFLOOR to first floor achieved 7 stars with the following: Ceiling insulation to R6.0 (Excl. Garage); External wall insulation to R2.5 (Excl. Garage); R2.0 insulation throughout the internal walls; 1 x 1200mm ceiling fans to Kitchen/Living/Dining; 1200mm ceiling fans to all Bedrooms, Rumpus, Media; Single Glazing Low-e Clear to all windows and sliding doors; R4.0 Insulation throughout the suspended floor

BASIC CONSTRUCTION DETAILS

FIGURE 1: ALPHAFLOOR CONFIGURATION

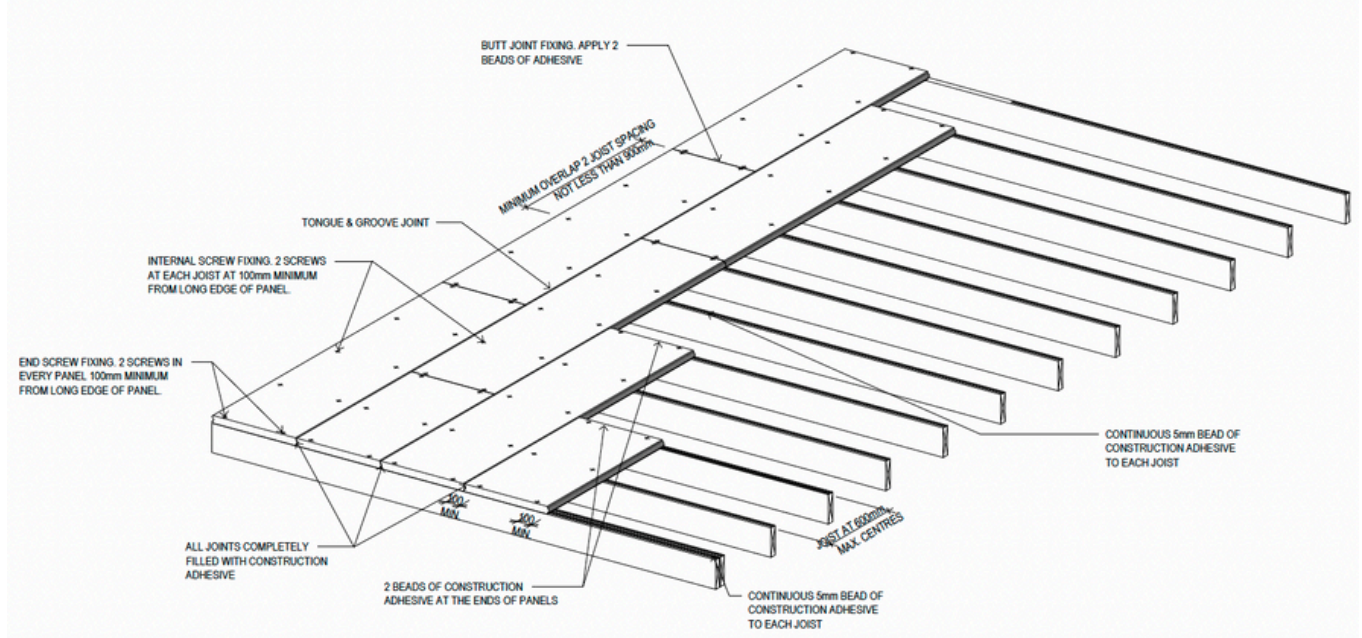
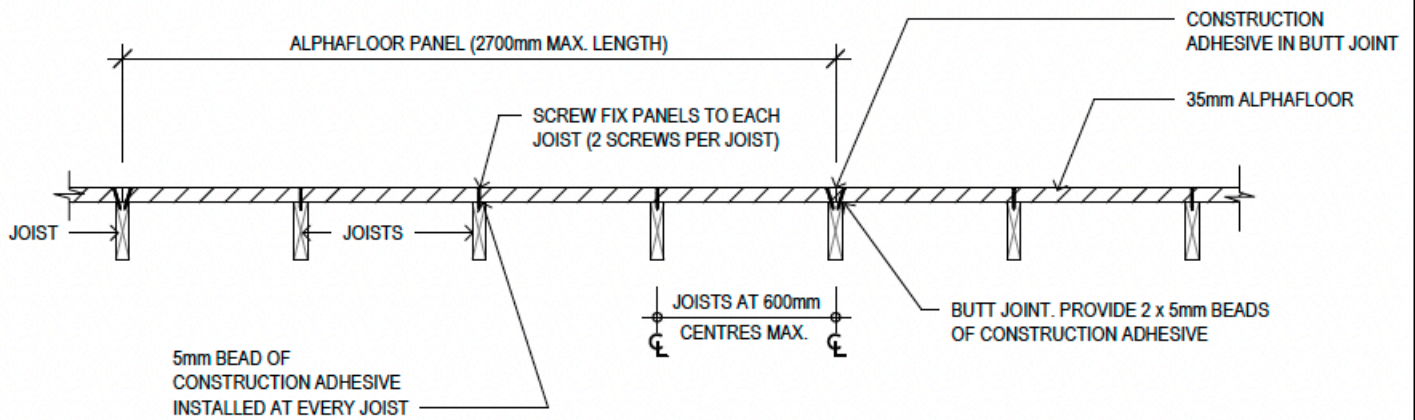

FIGURE 3: FLOOR SECTION - PERPENDICULAR TO JOISTS



Please refer to the ALPHAFLOOR TECHNICAL & INSTALLATION MANUAL for complete construction and installation details.

ALPHAFLOOR®

XCEM PTY LIMITED

WWW.XCEM.COM.AU
INFO@XCEM.COM.AU
1800 88 XCEM (9236)