



# TECHNICAL & INSTALLATION MANUAL

# ALPHAFLOOR®

THE SOLID CONCRETE FLOOR PANEL

# CONTENTS

<b>1. TECHNICAL SPECIFICATIONS</b>	<b>3</b>
<b>2. KEY INSTALLATION STEPS</b>	<b>4</b>
<b>3. INSTALLATION DETAILS</b>	<b>6</b>
<b>4. CONSTRUCTION DETAIL</b>	<b>7</b>
<b>5. CONSTRUCTION NOTES</b>	<b>9</b>
<b>6. WHS/PPE/PRODUCT WARRANTY NOTES</b>	<b>10</b>
<b>7. MODELLING ALPHAFLOOR FOR NATHERS</b>	<b>11</b>

# TECHNICAL SPECIFICATIONS

ALPHAFLOOR® is a solid precast concrete panel made using XCEM® concrete technology. It presents a hard, smooth surface. Table 2.1 contains the material properties of ALPHAFLOOR®. Testing was carried out by a laboratory accredited by NATA for Technical Competence (Accreditation No. 1393, Site No. 1386). The determination of characteristic strength and connection capacity values has been carried out in accordance with AS/NZS1170.0 Appendix B.

## ALPHAFLOOR®

PRODUCT	PANEL WIDTH	AVAILABLE LENGTHS (MM)	# PANELS PER PACK
35MM ALPHAFLOOR®	570MM	2700MM	14

Design Density: 40.79 kg/m<sup>2</sup>

Transport & Construction Density: 52 kg/m<sup>2</sup>

XCEM ALPHAFLOOR is a precast concrete panel. Tolerances on the manufactured product are:

- Panel short edges +/- 4mm tolerance
- Panel long edges +/- 4mm
- Panel thickness within + 1.5mm tolerance

## LOAD CAPACITY OF ALPHAFLOOR®

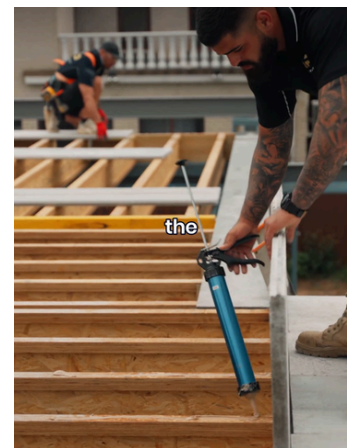
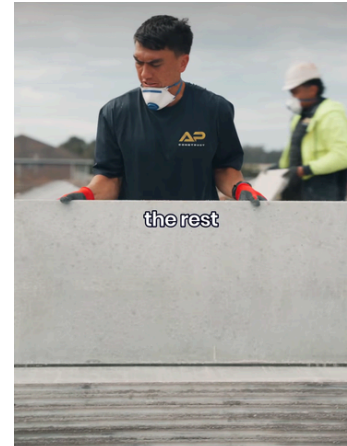
Application	Permanent Actions Included in Application (35mm)	Distributed Imposed Action Q	Concretrated Imposed Action Q <sub>c</sub> (area distributed over)	Maximum Joist Spacing for AlphaFloor®
Residential Activities - General Areas	G <sub>sw</sub> = 0.40 kPa G <sub>r</sub> = 0.25 kPa G <sub>s</sub> = 0.50 kPa	1.5 kPa	1.8 kN (350 mm <sup>2</sup> )	600 mm
Residential Activities - Tiled Wet Areas	G <sub>sw</sub> = 0.40 kPa G <sub>r</sub> = 0.50 kPa G <sub>s</sub> = 0.50 kPa	1.5 kPa	1.8 kN (350 mm <sup>2</sup> )	500 mm
Residential Activities - Balconies and Verandahs	G <sub>sw</sub> = 0.40 kPa G <sub>r</sub> = 1.00 kPa G <sub>s</sub> = 0.50 kPa	2.0 kPa	1.8 kN (350 mm <sup>2</sup> )	450 mm
Light Commercial Activities	G <sub>sw</sub> = 0.40 kPa G <sub>r</sub> = 1.00 kPa G <sub>s</sub> = 0.50 kPa	3.0 kPa	2.7 kN (0.01 m <sup>2</sup> )	450 mm

### Notes:

1. G<sub>sw</sub> = permanent action due to self-weight of ALPHAFLOOR - 0.40 kPa 35mm
2. G<sub>r</sub> = permanent action of applied floor coverings
3. G<sub>s</sub> = permanent action allowance for superimposed loading of permanent fixtures
4. Applicable factored load case for strength: 1.2G + 1.5Q

# KEY INSTALLATIONS STEPS

- Ensure Safety Rails are installed
- Joists Set out at 450mm centres and level, the panel can span 600mm, however panel length is 2700mm long which works best at 450mm centres, so to minimise cutting and waste, 450mm is recommended.
- The Tonge and Groove are offset from the centre of the panel. The panels are packaged so that the face with the thinner groove edge is face up. Panels are to be installed so that this face is face up.
- Panels to be Carried on Edge Only. Support the panel in the centre when tilting or rotating.
- Cut using a Masonry Blade - Use minimum P1 Mask
- Install in Stretcher Bond Pattern
- Min. panel width when trimmed shall be 200 mm. Trim to maintain T&G edge profiles.
- Adhesive Applied in T&G, On Joists and in Butt Joints of Panels
- Ensure Panel End land on a Joist
- Panel is screwed 100mm in from both long edges wherever it touches a joist. 2 x Screws per joist location/per panel, each panel will have 14 screws.
- ALPHAFLOOR sheets have dimensional tolerance. When installing, engage the Tonge and Groove, however engage it in a position which allows the installation contractor to keep a straight line. Do not hammer it all the way in if this will cause the sheets to go off line.



# KEY INSTALLATIONS STEPS

- After installing all the sheets fill in any minor gaps using construction adhesive.
- Ensure Control Joints are installed at the following locations:
  - For Carpet and Timber Floor coverings, max. 12,000 mm grid internal, ensuring any wet areas are isolated.
  - Where movement could affect the floor covering e.g., Tiles - internal control joint spacing in accordance with tile specification or alternatively provide a membrane and flexible tile bed/adhesive solution that can accommodate substrate movement.
  - Max. 4,500 mm grid external.
  - A change in floor thickness.
  - Corresponding to supporting structure steps or control joints.
  - Junctions of different floor system types.
  - Over structural beams supporting the floor framing members.
- Seal control joints with backing rod and compatible sealant, 10 mm width x 5 mm depth. Follow sealant manufacturers specifications.
- ALPHAFLOOR sheets have a thickness tolerance on them, if installing direct stick flooring or carpet, allow to have the floor sanded using a standard upright drum sander with 24grit or 40grit paper as would typically be done with particleboard flooring.



# INSTALLATION DETAILS

## FIXING OPTIONS ALPHAFLOOR®

### Timber Joists

- Bremick Screw Decking Shark Tooth 10x65mm;
- Strong Tie - DSVT212S - 10g x 65mm Quikguard® Coated (Collated for Quik Drive®) or loose
- Macsim: 10g X 65mm Decking Screw Nail Point SS304
- Strong Tie - SSDHSD65TSA 12g x 65mm SS316
  
- Adhesive: Construction adhesive or Polyurethane based adhesive.

### Steel Joists

- Quick Drive Screws - Strong-Tie - CBSDHG214SA 10g x 55mm Gal Winged Self Drilling Screw
- Hobson DRiLLX Metal Wings Screw 10G x 60mm Countersunk Square HOBT9PG3RQ1016060
  
- Recommended Adhesive: HB Floor Bond Fuller XMS

## CUTTING & SANDING ALPHAFLOOR®

**Cutting:** Track Saw / Diamond Holesaw / Masonry Circular Saw

**Sanding:** Sand using Floor or Belt sander (Grit 24)

## FIXING FRAMING BOTTOM PLATE TO ALPHAFLOOR®

**Timber Framing:** As per Nominal fixings for timber wall framing to timber joists as specified in AS 1684.2:2021 the fastener shall be embedded min. 40mm into the timber framing member. Equivalent for screw – No. 8 or No. 10 with sufficient length to go through wall bottom plate, ALPHAFLOOR and embed minimum 40mm in the timber framing member – for 35mm bottom plate and 35mm ALPHAFLOOR this is min. 110mm screw length.)

Note, for non-loadbearing partition walls that are also not braced, it is permissible to nail through the 35-38mm thick timber bottom plate to ALPHAFLOOR using 1x dia.2.87 x 65mm framing nails at 300 mm ctrs. Note - 1 x nail at 300mm ctrs. is equivalent to 2x nails at 600mm ctrs. per nominal fixing table, but is preferred.

**Steel Framing:** No. 14-10 Hex head Tek Screw about 55-65mm length for general fixing. Assuming steel bottom plate. NASH standard should be followed for high strength hold down which need plate washers/brackets to studs and possible through bolts. As a guide should have 3 x threads stocking through the steel on the drill point end.

## INSTALLATION OF CARPET

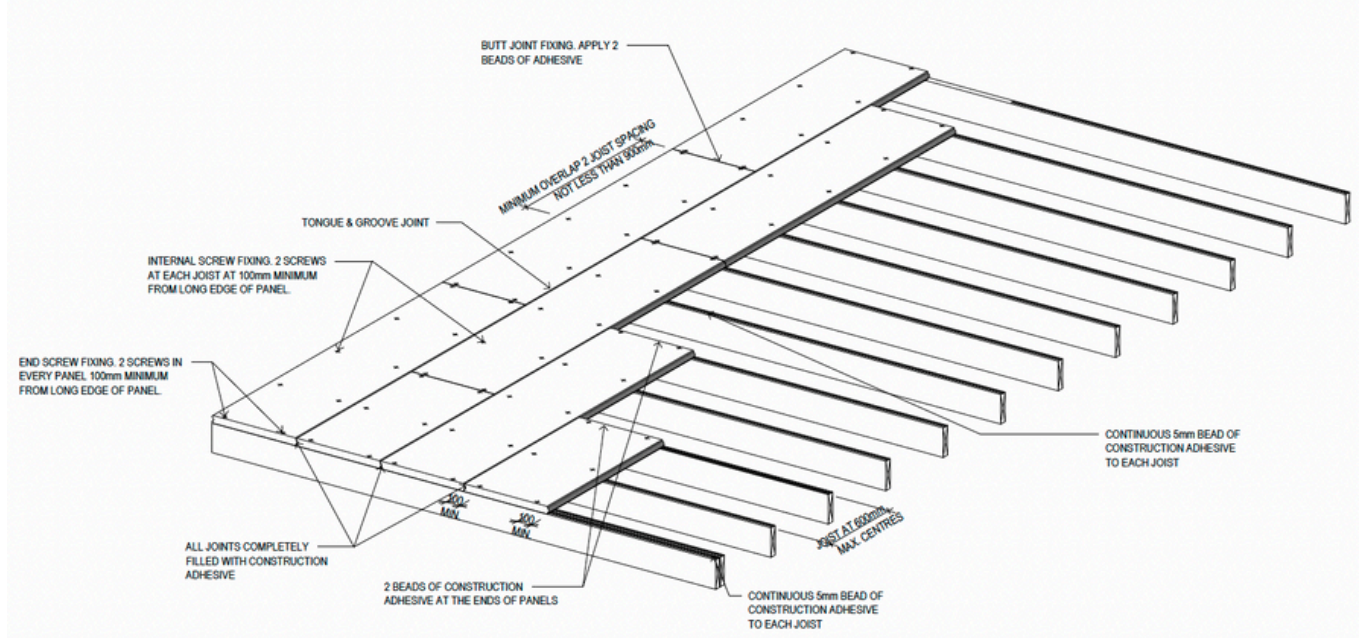
ALPHAFLOOR can be nailed. Use timber/wood smoothedge/carpet gripper with timber nails, which have good connection strength in ALPHAFLOOR.

## WATERPROOFING

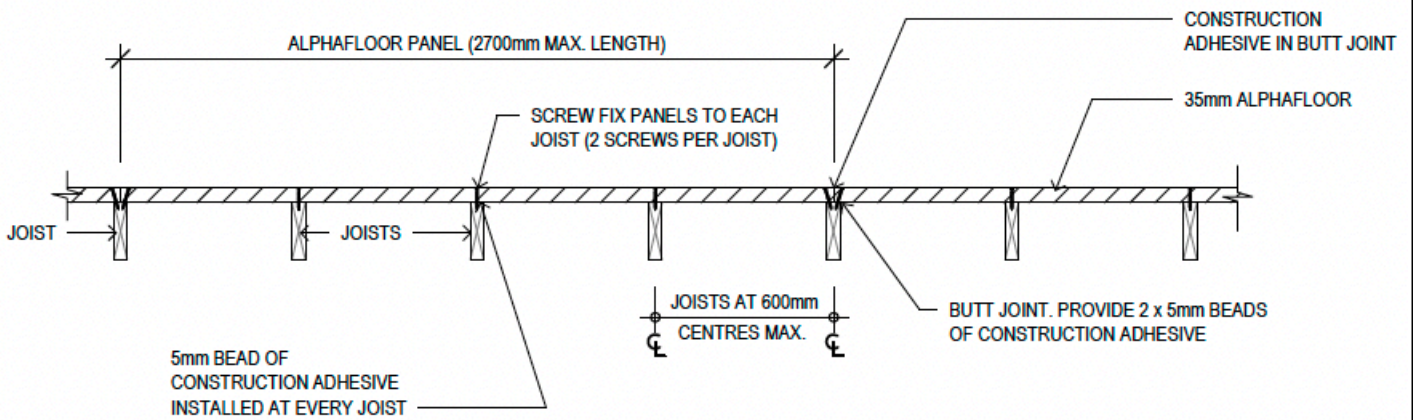
ALPHAFLOOR and framing members must be constructed above the DPC, and exposed floor areas on verandahs and balconies must be fully sealed with a waterproof tanking membrane to all exposed ALPHAFLOOR surfaces in accordance with the supplier's specifications prior to installation of tiling or other floor surface finishing. The tanking membrane shall not be penetrated by fixings after application. Waterproofing of verandahs and balconies shall be carried out in accordance with AS 4654.2 using membranes that comply with AS 4654.1. Separate protection of framing members may be necessary – refer to supplier's specifications for verandah and balcony applications. Internal wet areas shall be detailed and waterproofed.

# CONSTRUCTION DETAILS

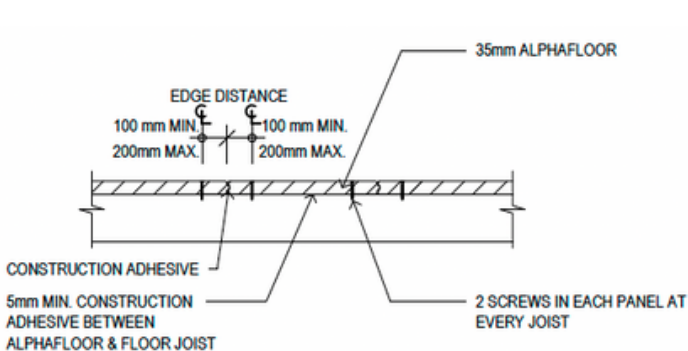
**FIGURE 1: ALPHAFLOOR CONFIGURATION**



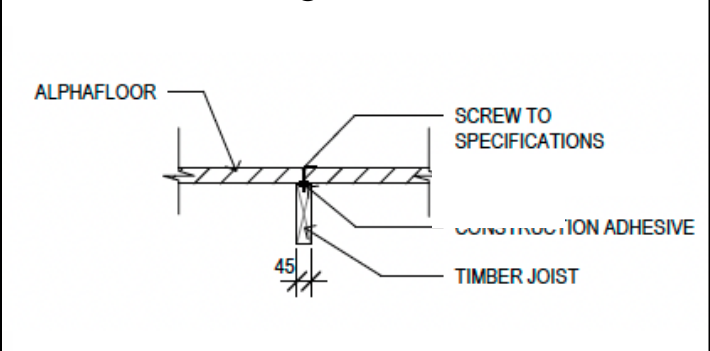
**FIGURE 3: FLOOR SECTION - PERPENDICULAR TO JOISTS**



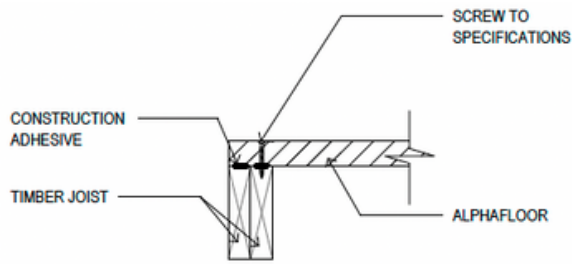
**FIGURE 4: FLOOR SECTION - PARALLEL TO JOISTS**



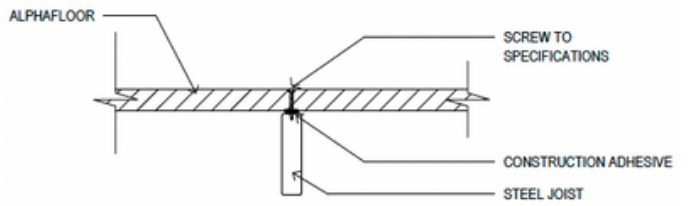
**FIGURE 5: ALPHAFLOOR® FIXING TO TIMBER JOISTS**



**FIGURE 6: ALPHAFLOOR® FIXING AT END OF PANELS TO TIMBER JOISTS**

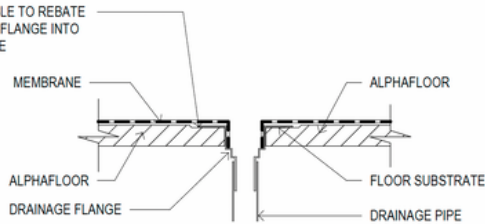


**FIGURE 7: ALPHAFLOOR® FIXING TO STEEL JOISTS**

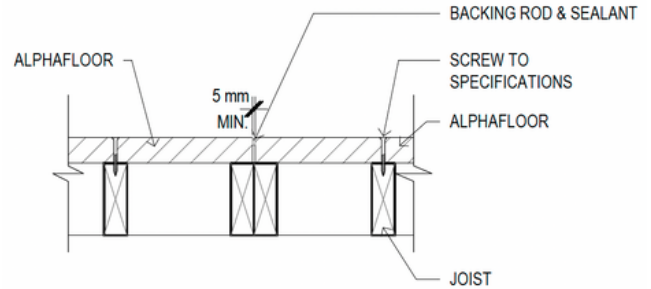


**FIGURE 8: MEMBRANE TERMINATION AT DRAINAGE FLANGE**

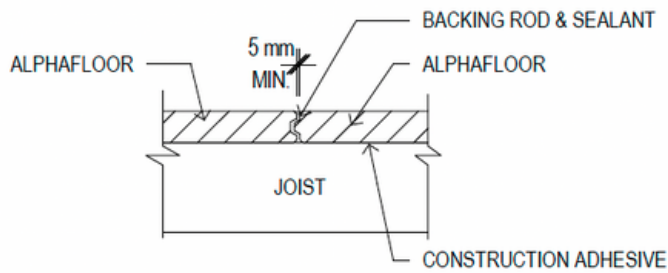
IT IS PREFERABLE TO REBATE THE DRAINAGE FLANGE INTO THE SUBSTRATE



**FIGURE 9: CONTROL JOINT AT PANEL END**

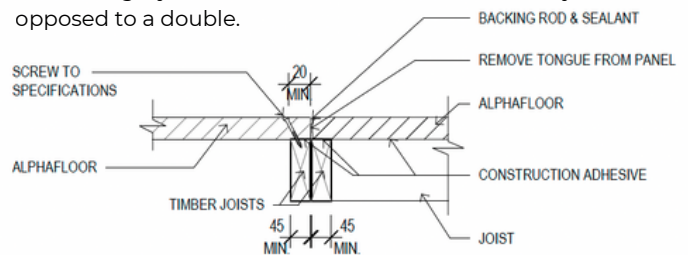


**FIGURE 10: CONTROL JOINT AT PANEL EDGE**

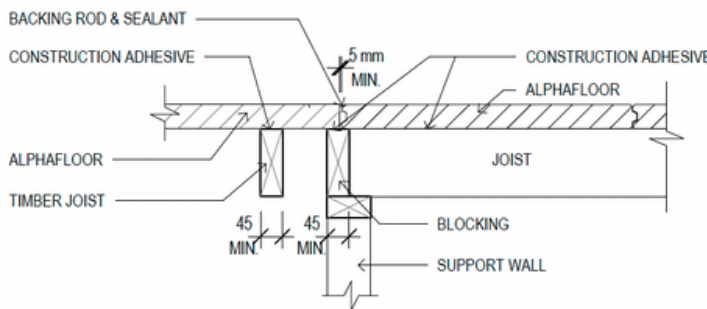


**FIGURE 11: ALPHAFLOOR® FIXING AT END OF PANELS TO TIMBER JOISTS**

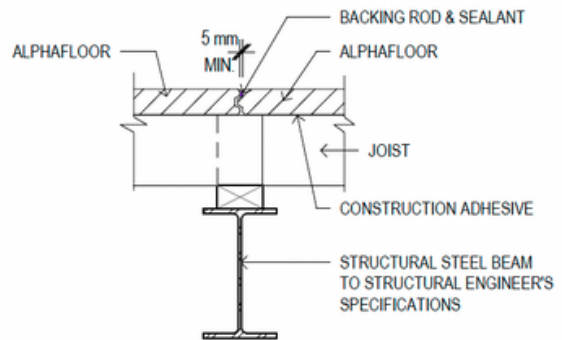
\*Note that if the joist is a minimum of 63mm wide at the top, then a single joist can be utilised under the control joint, as opposed to a double.



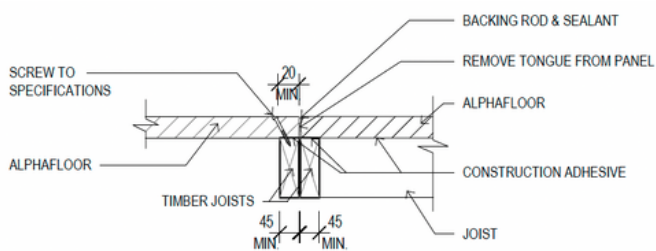
**FIGURE 12: ALPHAFLOOR® CONTROL JOINT LOCATION AT CHANGE IN JOIST ORIENTATION**



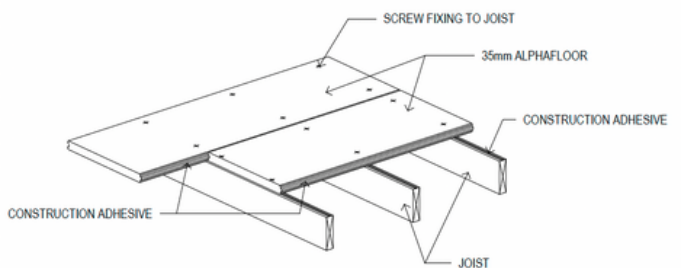
**FIGURE 13: ALPHAFLOOR® CONTROL JOINT OVER STRUCTURAL STEEL BEAM**



**FIGURE 14: ALPHAFLOOR® FIXING AT ALTERNATIVE END OF PANELS TO TIMBER JOISTS**



**FIGURE 15: ALPHAFLOOR COMPONENTS**



## CONSTRUCTION NOTES

The Installer shall refer to the project drawings and specifications and shall perform work to the quality standards agreed with the builder. The notes below are important from a structural engineering and compliance perspective.

1. Framing shall be in accordance with the required standards for timber or cold-formed steel as per Load Capacity Table, designed to support the permanent action of ALPHAFLOOR® and other linings or permanent fixtures plus required imposed actions, and any other actions as applicable. Consult the project engineer for appropriate loading requirements.
2. Verandah and balcony framing shall be constructed so as to provide the necessary fall away from the external wall of the building. Structural members shall be protected from moisture by flashings and DPC as required.
3. Timber joists shall be min. 40 mm wide. Steel joists shall be min. 50 mm wide.
4. Line loads and concentrated point loads shall have a structural support pathway directly under ALPHAFLOOR®.
5. Structural bracing and hold-down of wall frames shall be carried through to the floor framing members.
6. All joists shall be level and flat to provide even bearing for support of ALPHAFLOOR®.
7. Panel ends in the field of the floor shall be evenly supported on a joist with 20 mm minimum bearing to each panel end. Ensure construction adhesive bonds both sheets to the joist and fill gap with bonding compound, filler or sealant.
8. Min. panel width when trimmed shall be 200 mm. Trim to maintain T&G edge profiles.
9. ALPHAFLOOR® is to be laid out over the floor in a stretcher bond manner.
10. ALPHAFLOOR® is to be joined with construction adhesive applied in the tongue and groove edge joints and End Joints.
11. For joints where the tongue and groove joint has been cut away and not reinstated, provide joist section or 90x45 MGP10, or similar, trimmers between the joists to support the joint.
12. Provide control joints (min. 10 mm wide) in ALPHAFLOOR® at the following locations:
  - 12.1. For Carpet and Timber Floor coverings, max. 12,000 mm grid internal, ensuring any wet areas are isolated. Where movement could affect the floor covering e.g., Tiles - internal control joint spacing in accordance with tile specification or alternatively provide a membrane and flexible tile bed/adhesive solution that can accommodate substrate movement.
  - 12.2. Max. 4,500 mm grid external.
  - 12.3. A change in floor thickness.
  - 12.4. Corresponding to supporting structure steps or control joints.
  - 12.5. Junctions of different floor system types.
  - 12.6. Over structural beams supporting the floor framing members.
13. Control joints perpendicular to the ALPHAFLOOR® span direction shall have 2 x joists, one under each sheet, unless the joist is a minimum of 63mm wide at the the top. If the joist is a minimum of 63mm wide then a single joist can be utilised.
14. Seal control joints with backing rod and compatible sealant, 10 mm width x 5 mm depth.
15. Provide a light gauge steel angle trim (min. 30 x 30 x 1.0 mm) to the leading edge of ALPHAFLOOR® at exposed edges, eg. top of stairs.
16. Waterproofing of finished ALPHAFLOOR® floors for wet areas shall be done in accordance with NCC Volume One 3.8.1.2 and AS 3740 using products compatible with ALPHAFLOOR® material. Provide a bond breaker tape over sealant joints in the floor and at wall junctions and corners.
17. Waterproofing of finished ALPHAFLOOR® shall be done using membranes complying with AS 4654 Part 1 that are compatible with ALPHAFLOOR®, and installed in accordance with AS 4654 Part 2. Provide a bond breaker tape over sealant joints in the floor and at wall junctions and corners.
18. Control joints in the floor shall be expressed through floor tile systems.

## WORKERS HEALTH & SAFETY

Please download ALPHAFLOOR® Material safety data sheet (MSDS) from [www.xcem.com.au/download](http://www.xcem.com.au/download)

### CUTTING OF ALPHAFLOOR®

ALPHAFLOOR® can be very easily cut on-site using a Masonry blade. ALPHAFLOOR® products have been analysed and assessed by HIBBS & Associates (certified occupational hygienists) for traces of crystalline silica. The ALPHAFLOOR® does not contain measurable levels of crystalline silica, therefore worker exposure to that risk when handling and processing is unlikely to occur. Crystalline silica is categorised as a health hazard when it's in a respirable form, such as occurs when cutting, grinding, and drilling. Refer to HIBBS report S11606-L1 for full details and limitations.

### MANUAL & TROLLEY ASSISTED HANDLING

ALPHAFLOOR® are to be handled and worked on-site as per similar generally accepted masonry and panel units, with installation contractors providing relevant safe work method statements.

XCEM recommends using a panel trolley and any other mechanical apparatus to assist with movement of the panels. Physical & manual movement of ALPHAFLOOR® should be kept to a minimum. Contractors must provide adequate support to the panels when lifting off the horizontal or tilting.

### PERSONAL PROTECTION

**Eye/Face:** For dust generating work, wear safety glasses with side shields or dust-proof goggles.

**Hand:** For dry handling/work, use any work-compatible protective gloves.

**Body:** Wear long sleeve shirt and full-length pants, or full coveralls. Where a body part is likely to be in contact with wet product.

**Respiratory:** For dust generating work (e.g. cutting, drilling, crushing, cleaning, etc.), use Class P1 (Particulate) respirator at minimum. Respiratory protective equipment should be selected based on an assessment of the working conditions (conducted by a competent person and should be informed by occupational hygiene exposure assessment results). Refer to AS/NZS 1715.

### INSTALLATION AND PRODUCT NOTES

1. ALPHAFLOOR is a raw precast concrete product, it is not a pre-finished product and is designed for use as a substrate only.
2. The Tongue and Groove are offset from the centre of the panel. The panels are packaged so that the face with the thinner groove edge is face up. Panels are to be installed so that this face is face up.
3. When carrying the panel, ensure it is carried on edge. Carrying it on the flat may cause cracking of the panel. Support the panel in the centre when tilting or rotating.
4. The pre-cast panel as delivered may contain pin holes, or bug holes in the panel surface. These surface defects do not adversely impact the performance of the product in regards to compliance requirements. This does not constitute a product issue that can be claimed under warranty.
5. Because ALPHAFLOOR is a cementitious product, the product may be subject to minor surface cracking, such as craze cracking and minor horizontal cracks. All performance testing of the product was conducted with such cracking evident in the panel, so the appearance of these cracks in no way impacts the product in regards to compliance requirements. The panel is reinforced with Glass Fibre. Surface cracking in the panel does not constitute a product issue that can be claimed under warranty.
6. If required the panel surface can be sanded using a floor sander with 24grit paper. Sanding can be performed down to not less than 32.5mm thickness.

# MODELLING ALPHAFLOOR FOR NATHERS

ALPHAFLOOR has been approved by NatHERS and added into the NatHERS Material library. It is listed under the new material "Fibre reinforced concrete (Thermal conductivity = 0.28 W/mK, Heat Capacity 1.172 J/gK) option for ALPHAFLOOR".

Incorporation of ALPHAFLOOR generally adds 0.2 - 0.5 star rating compared to traditional flooring due to its significant thermal mass contribution (depending on orientation, climate zone etc.).

Below is how ALPHAFLOOR is modelled in the various software providers:

- BERS Pro: 35mm XCEM ALPHAFLOOR is available as a standard floor assembly option "35mm fibre reinforced concrete floor".
- Hero: 35mm XCEM ALPHAFLOOR is available as a standard floor assembly option "35mm ALPHAFLOOR".
- FirstRate 5: NatHERS have advised that when using FR5 35mm ALPHAFLOOR to be modelled as 42mm Fibre Cement (Not Compressed Fibre Cement). First Rate 5 have advised that they will look to add ALPHAFLOOR in the next minor update, at which point the users will need to select "35mm Fibre Reinforced Concrete" as opposed to 42mm of FC.

**ALPHAFLOOR®**

**XCEM PTY LIMITED**

**WWW.XCEM.COM.AU**  
**INFO@XCEM.COM.AU**  
**1800 88 XCEM (9236)**